

REV.	ECN.NO.	MODIFY.CONTENT	DATE
X2		FIRST VERSION	

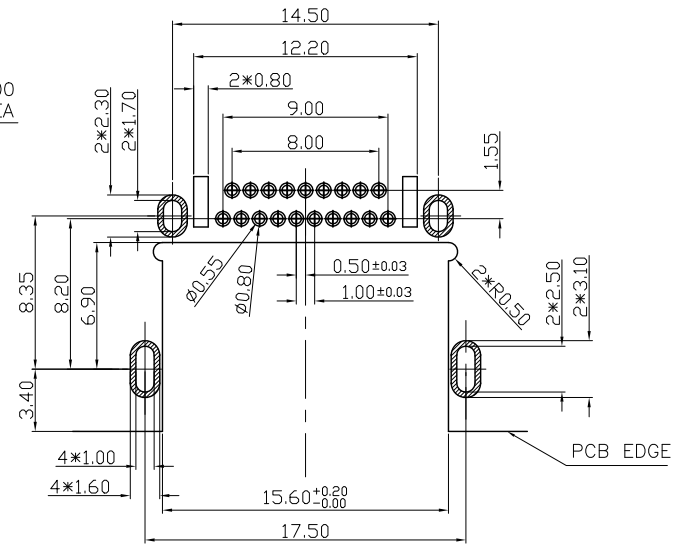

- NOTES:
- MATERIAL:
HOUSING:LCP OR OTHER EQUIVALENT HIGH PERFORMANCE RESINS G/F FILLED,UL94 V-0 RATED
TERMINAL:COPPER ALLOY
SHELL:STEEL OR OTHER EQUIVALENT PERFORMANCE ALLOY
 - PLATING:
SELECTIVE GOLD PLATING IN THE CONTACT AREA AND SELECTIVE TIN PLATING IN THE SOLDER TAIL AREA WITH 50u" NICKEL UNDERPLATING OVERALL
SHELL: Ni 50u" MIN. UNDER PLATED OVER ALL
 - DURABILITY CYCLES: 10000 TIMES
 - INSERTION FORCE: 44.1N(4.5kgf) MIN.
 - EXTRACTION FORCE:
INITIAL:9.8N(1.0kgf)~39.2N(4.0kgf)
AFTER 2001 TO 10000 CYCLES:4.9N(0.5kgf)~39.2N(4.0kgf)
 - SALT SPRAY: CONTACT AREA 48H
 - PART NUMBER DESCRIPTION:

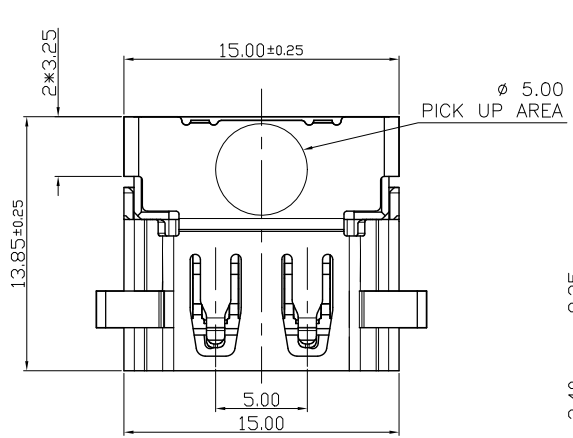
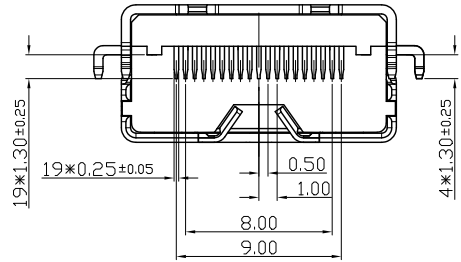
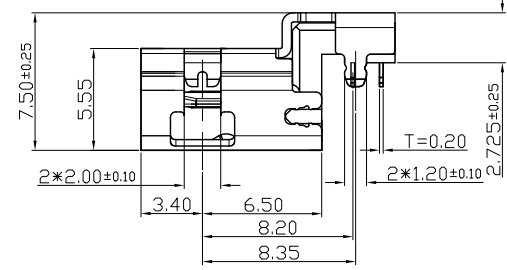
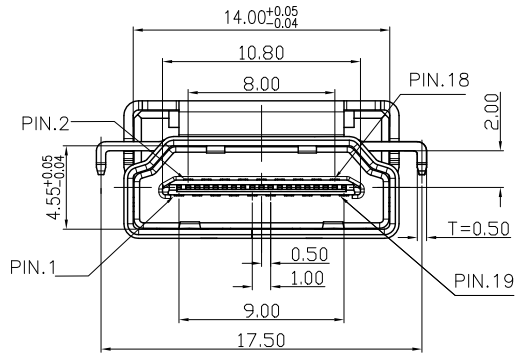

1HDM051 * 19 R 1 R-HF
 Plating:
 F:Gold Flash
 E:Au:5u"
 J:Au:15u"
 K:Au:30u"

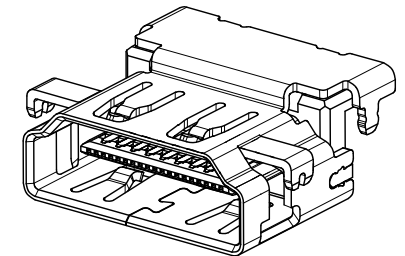
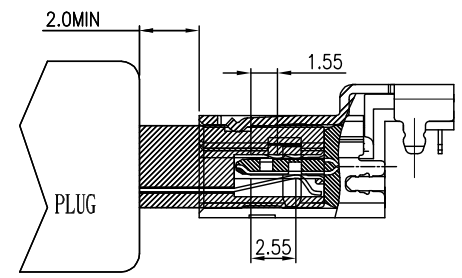
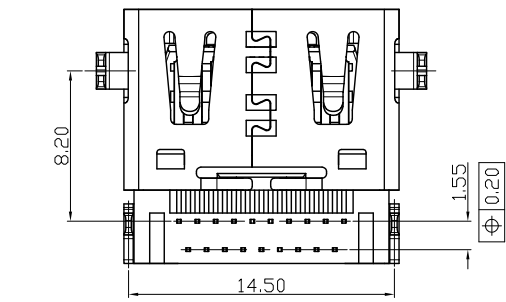

3D VIEW

GENERAL TOLERANCE		DRAWN	HJ.Wang	08/30'20	SCALE	PART NO.	1HDM051F19R1R-HF
X.±0.30	x.*±2.0'	CHECKED	Ray Lee	08/30'20	1:1	TITLE	HDMI 2.1 TYPE A BY DIP TYPE CH=-2.00mm
.X±0.25	.x*±1.0'	APPROVED	Murray.lu	08/30'20	UNITS	mm	CUSTOMER DRAWING
.XX±0.15	.xx*±0.5'	File NO.	HDM05101S				
.XXX±0.10		REV.	蘇州祥龍嘉業電子科技股份有限公司				
SHEET	1/1	Q'TY	1	X2	Goldenconn Electronics Technology Co.,LTD		

此文件为双方检验的唯一标准
 This document is the only standard for inspection by both parties.

REV.	ECN.NO.	MODIFY.CONTENT	DATE
X2		FIRST VERSION	

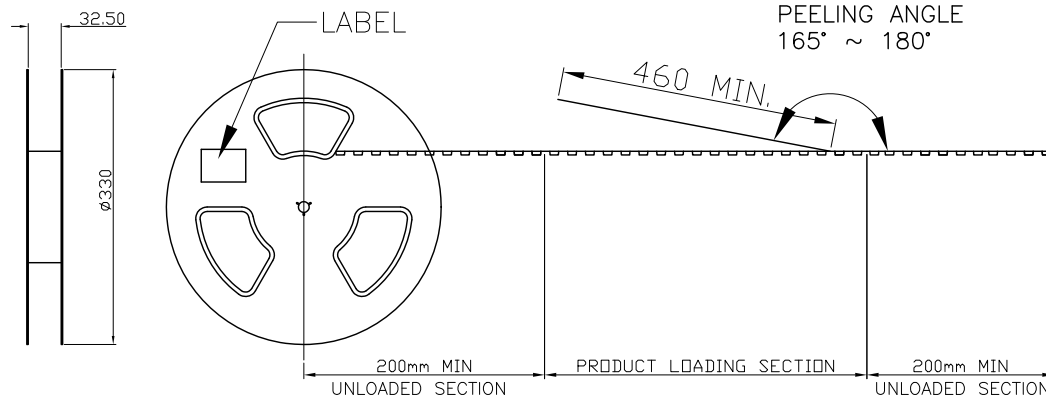

NOTES :

- MATERIAL :
COVER TAPE : P.S T=0.05mm
CARRIER TAPE : P.S T=0.40mm
CARTON: CORRUGATED FIBER
- DIMENSION :
REEL : SEE DRAWING
SHIPPING BOX: 350X350X300mm
- QUANTITY : SEE TABLE
- PEELING RESISTANCE : 10gf~130gf (for 12~56mm)
- PEELING SPEED : 300mm/MINUTES

User Direction of Unreeling

PULL OUT DIRECTION

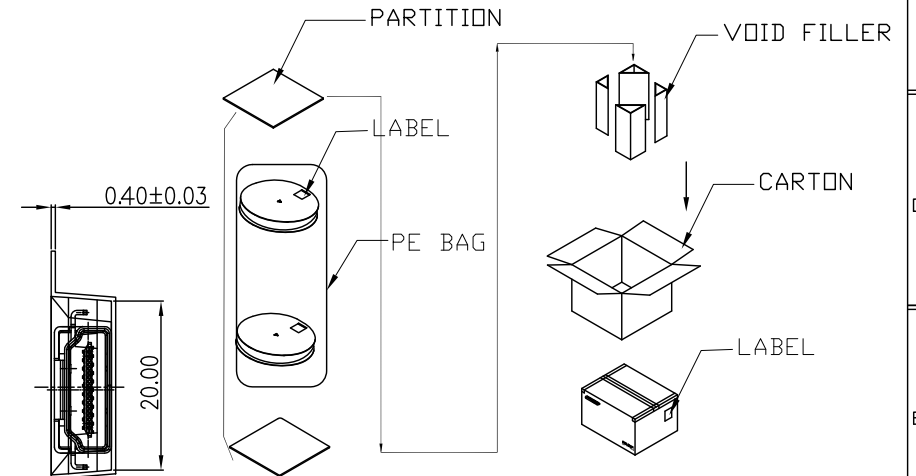
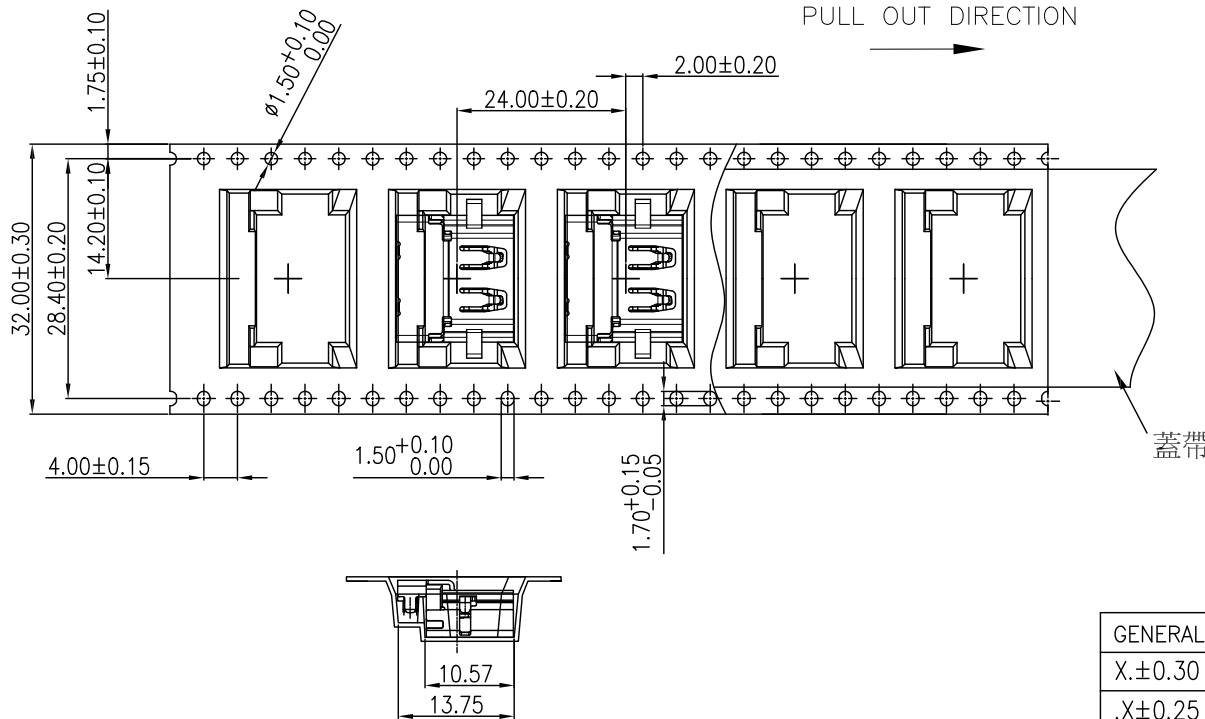

350	7	2450
PCS/REEL	REEL/BOX	TOTAL Q'TY

GENERAL TOLERANCE	DRAWN	HJ.Wang	08/30/20	SCALE	PART NO.	1HDM051F19R1R-HF
X.±0.30	x.*±2.0°	CHECKED	Ray Lee	08/30/20	TITLE	HDMI 2.1 TYPE A BY DIP TYPE CH=-2.00mm
.X±0.25	.x*±1.0°	APPROVED	Murray.lu	08/30/20	UNITS	mm
.XX±0.15	.xx*±0.5°	File NO.	HDM05101S		CUSTOMER DRAWING	
.XXX±0.10		REV.				
SHEET	2/2	Q'TY	1	X2	蘇州祥龍嘉業電子科技股份有限公司 Goldennconn Electronics Technology Co.,LTD	

此文件为双方检验的唯一标准
This document is the only standard for inspection by both parties.