

此文件为双方检验的唯一标准
This document is the only standard for inspection by both parties.

REV.	ECN.NO.	MODIFY.CONTENT	DATE
X1		/	10/25'19
X2		Revised the casting part for pcb pad	11/09'19

Shown as: 1FABV02HU1PK3MHF

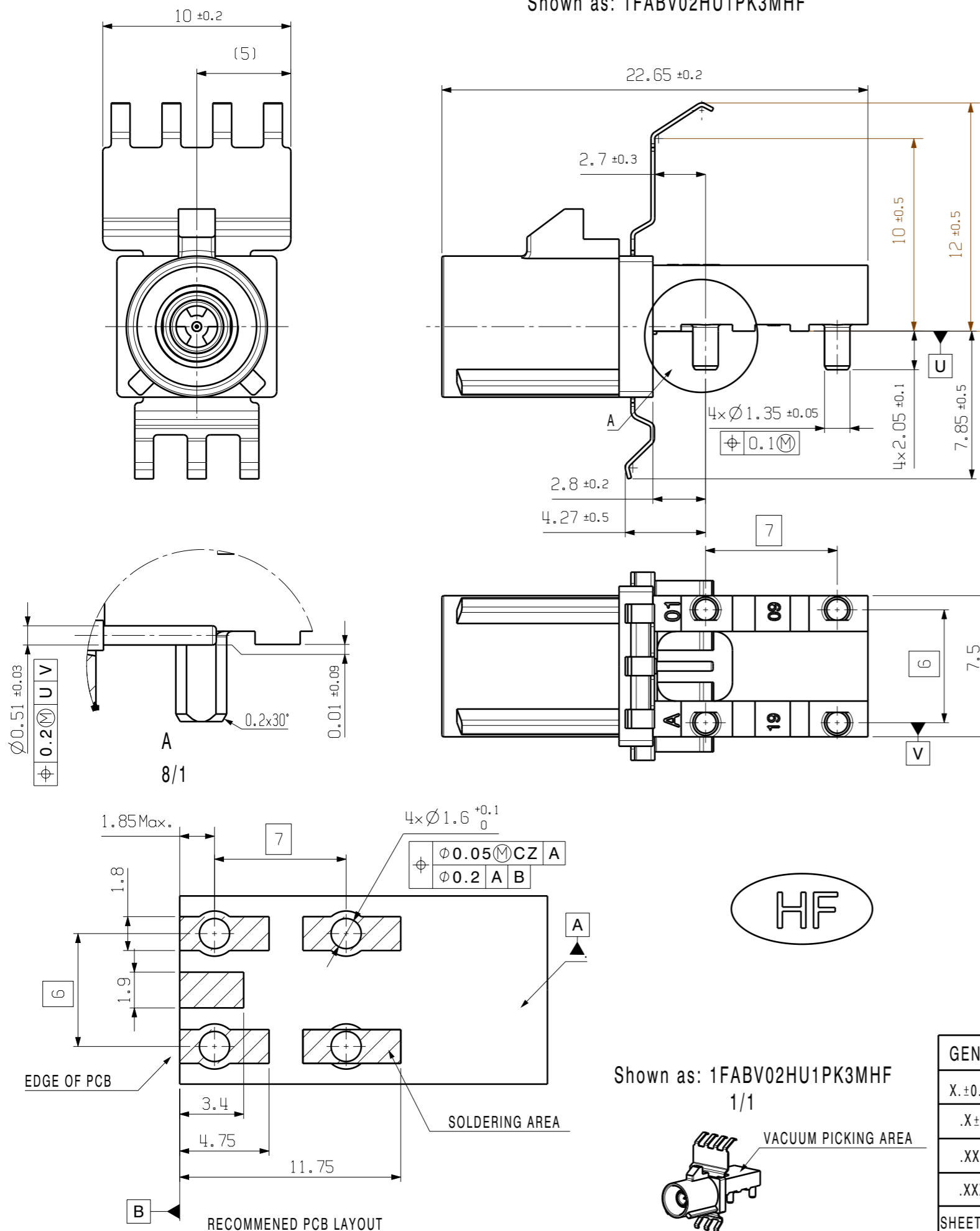

NOTE:

- INTERFACE**
ACC. TO DIN72594-1.THE CONFIGURATION OF THE CODINGS IS SHOWN ON SHEET 2.
- ELECTRICAL DATE**
 - IMPEDANCE: 50?
 - FREQUENCY: DC to 6 GHz
 - TEST VOLTAGE: 750 V rms
 - WORKING VOLTAGE: 335 V rms
 - POWER CURRENT: i 1 A DC
- MECHANICAL DATA**
 - MATING CYCLES: i 25
 - ENGAGEMENT FORCE: i 65 N
 - DISENGAGEMENT FORCE: i 2 N
 - RETENTION FORCE: i 110 N
 - CODING EFFICIENCY: i 40 N
- ENVIRONMENTAL DATA**
 - TEMPERATURE RANGE: -40 °C to +105 °C
 - THERMAL SHOCK: DIN 72594-2 clause 8.2
 - TEMPERATURE AND HUMIDITY: DIN 72594-2 clause 8.3
 - VIRBRATION AND MECHANICALSHOCK: DIN 72594-2 clause 8.1
 - DRY HEAT: DIN 72594-2 clause 8.4
 - SOLDERING PROFILE: ACC. to IEC 60068-2-58 group 3&4
 - RoHS /HALOGEN FREE: COMPLIANT
- MATERIAL AND PLATING :**
 - CORE PIN: BRASS GOLD PLATING
 - CORE PIN HOLDER: PA 6T BLACK
 - INTERFACE HOUSING: PA 6T COLOR REFER TO DIN72594-1
 - OUTER HOUSING: Zn ALLOY TIN PLATING
 - CONTACT SPRING: STAINLESS STEEL TIN PLATING
- PACKAGE: TAPE REEL**

Shown as: 1FABV02HU1PK3MHF
1/1

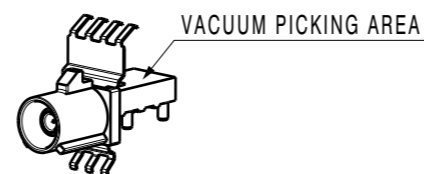

GENERAL TOLERANCE		DRAWN	Michael Wu	10/25'19	SCALE	PART NO.	1FABV02HU1P*3MHF
X. ±0.30	x.° ±3.0°	CHECKED	Michael Wu	11/09'19	4/1	TITLE	FAKRA R/A SINGLE POLE PLUG
.X ±0.25	.x° ±2.0°	APPROVED	Sky He	11/09'19	UNITS	mm	CODE NORMAL W/180 ° SHIELD PLA
.XX ±0.20		File NO.	FABV0201S				CUSTOMER DRAWING
.XXX ±0.10		REV.	蘇州祥龍嘉業電子科技股份有限公司				
SHEET	1/2	Q'TY	1	X2	Goldenconn Electronics Technology Co.,LTD		

此文件为双方检验的唯一标准
This document is the only standard for inspection by both parties.

REV.	ECN.NO.	MODIFY.CONTENT	DATE
X1		/	10/25'19
X2		Revised the casting part for pcb pad	11/09'19

ALL CODING RIBS SHOWN

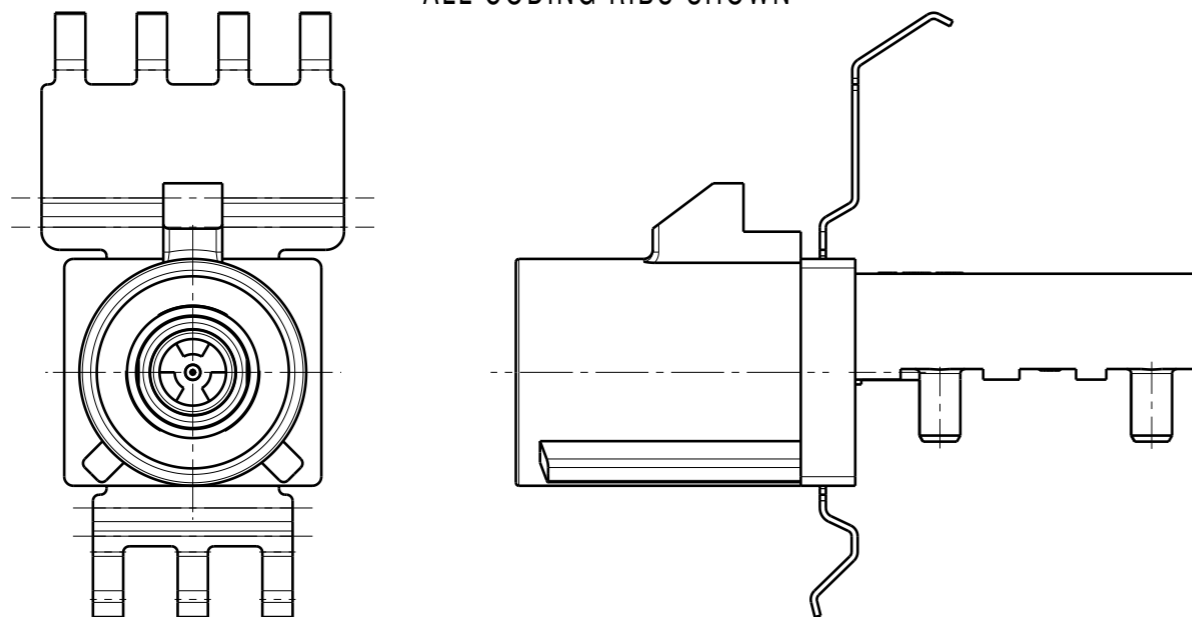

PRODUCT NAME RULE

1: FINISHED GOOD
FAB: FAKRA BOARD SIDE
V: W/ 180° SHIELDING PLATE
02: SEQUENTIAL CODE
H: GOLDEN PLATED

LATCH DIRECTION
U: UP
D: DOWN

POLE NUMBER
1: SINGLE POLES

HF=HALOGEN FREE
00=ROHS
SPECIAL TYPE
M = R/A SMD

PACKING:
3=TAPE RELL W/O MYLAR

CODING:
REFER TO ISO 20860-1 OR DIN72594-1

MATING TYPE
P=PLUG

1 FAB V 02 H U 1 P K 3 M HF

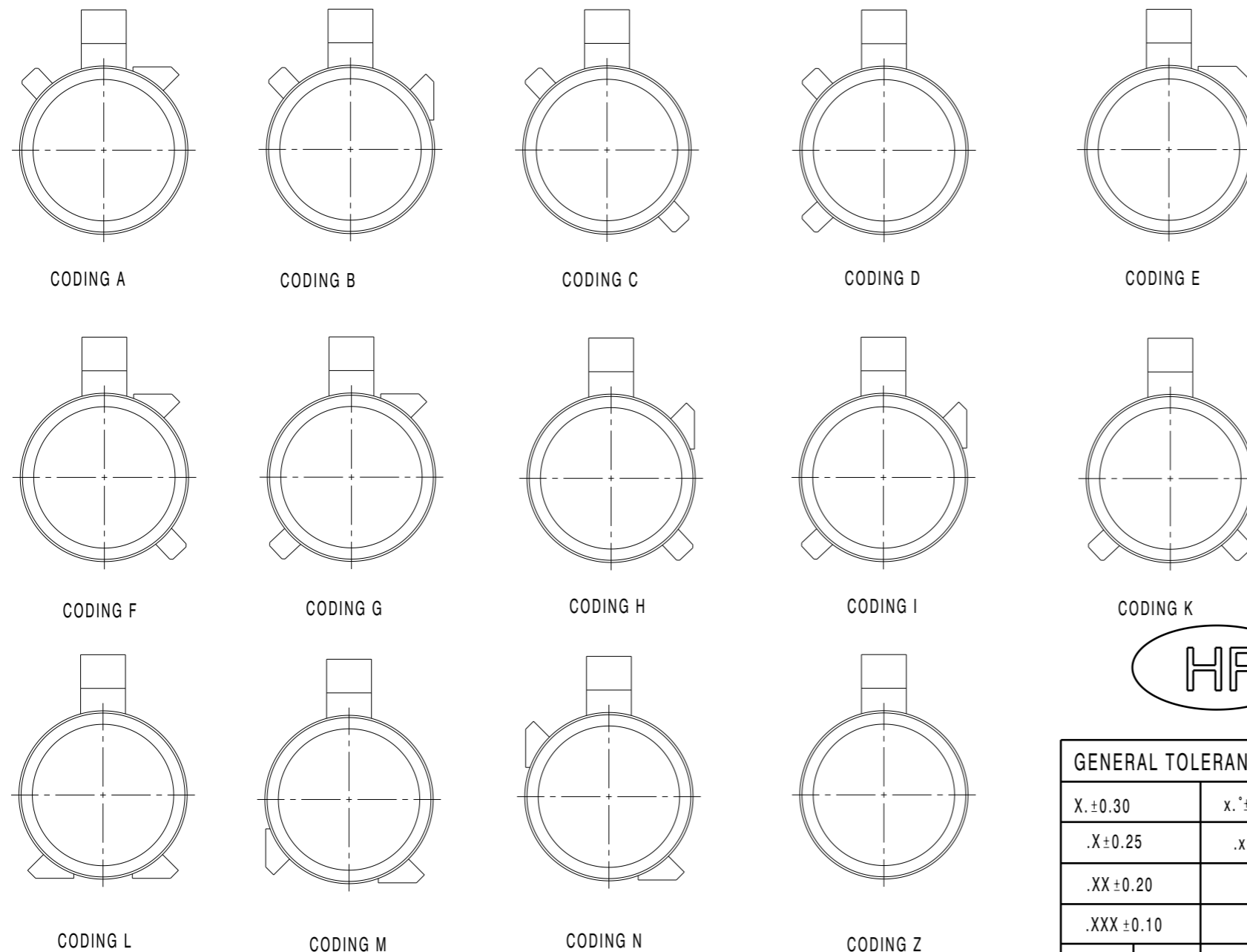

Coding	Color	RAL	Part Number
A	Black	RAL.9005	1FABV02HU1PA3MHF
B	White	RAL.9001	1FABV02HU1PB3MHF
C	Blue	RAL.5005	1FABV02HU1PC3MHF
D	Bordeaux violet	RAL.4004	1FABV02HU1PD3MHF
E	Green	RAL.6002	1FABV02HU1PE3MHF
F	Brown	RAL.8011	1FABV02HU1PF3MHF
G	Gery	RAL.7031	1FABV02HU1PG3MHF
H	Violet	RAL.4003	1FABV02HU1PH3MHF
I	Beige	RAL.1001	1FABV02HU1PI3MHF
K	Curry	RAL.1027	1FABV02HU1PK3MHF
L	Carmine-red	RAL.3002	1FABV02HU1PL3MHF
M	Pastel-orange	RAL.2003	1FABV02HU1PM3MHF
N	White-green	RAL.6019	1FABV02HU1PN3MHF
Z	Water blue	RAL.5021	1FABV02HU1PZ3MHF

GENERAL TOLERANCE		DRAWN	Michael Wu	10/25'19	SCALE	PART NO.	1FABV02HU1P*3MHF
X.±0.30	x.*±3.0°	CHECKED	Michael Wu	11/09'19	4/1	TITLE	FAKRA R/A SINGLE POLE PLUG
.X±0.25	.x.*±2.0°	APPROVED	Sky He	11/09'19	UNITS	mm	CODE NORMAL W/180 ° SHIELD PLA
.XX±0.20		File NO.	FABV0201S			CUSTOMER DRAWING	
.XXX±0.10		REV.	蘇州祥龍嘉業電子科技股份有限公司				
SHEET	2/2	Q'TY	1	X2	Goldenconn Electronics Technology Co.,LTD		