

此文件为双方检验的唯一标准  
This document is the only standard for inspection by both parties.

CODE REVERSED ORIENTATION

Shown as: 1FABN02HD1PK3MHF

REV.	ECN.NO.	MODIFY.CONTENT	DATE
X1		/	10/25'19
X2		Revised drawing	11/5'19

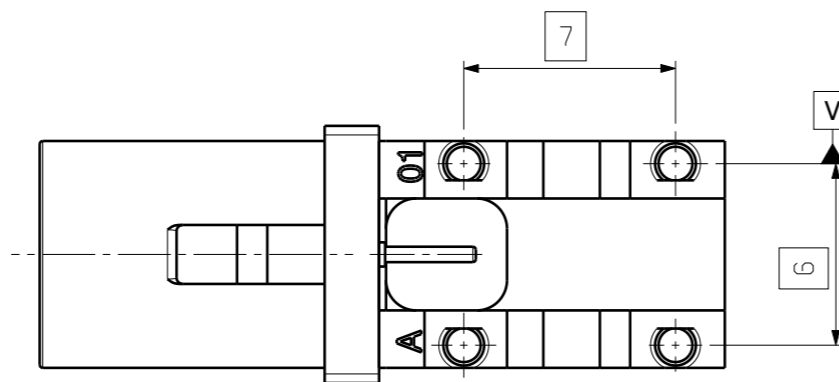
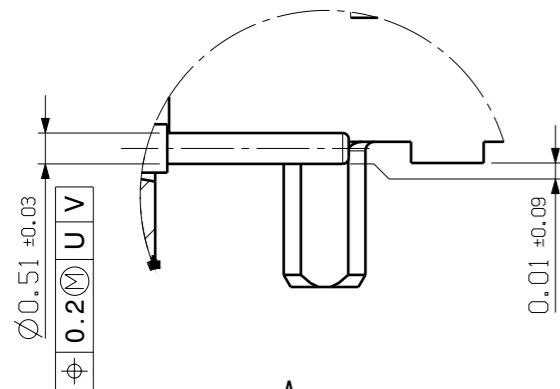
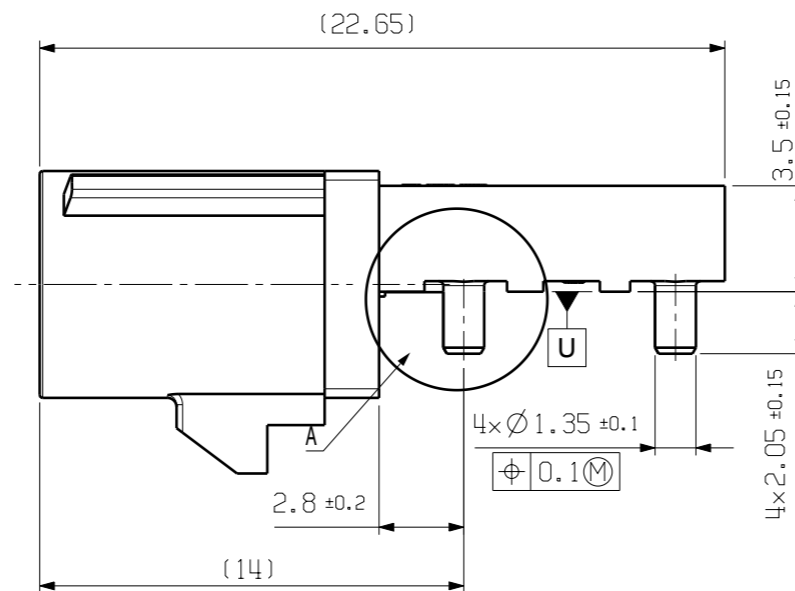
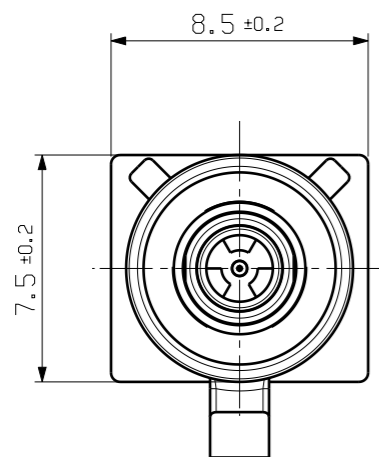

A  
8/1

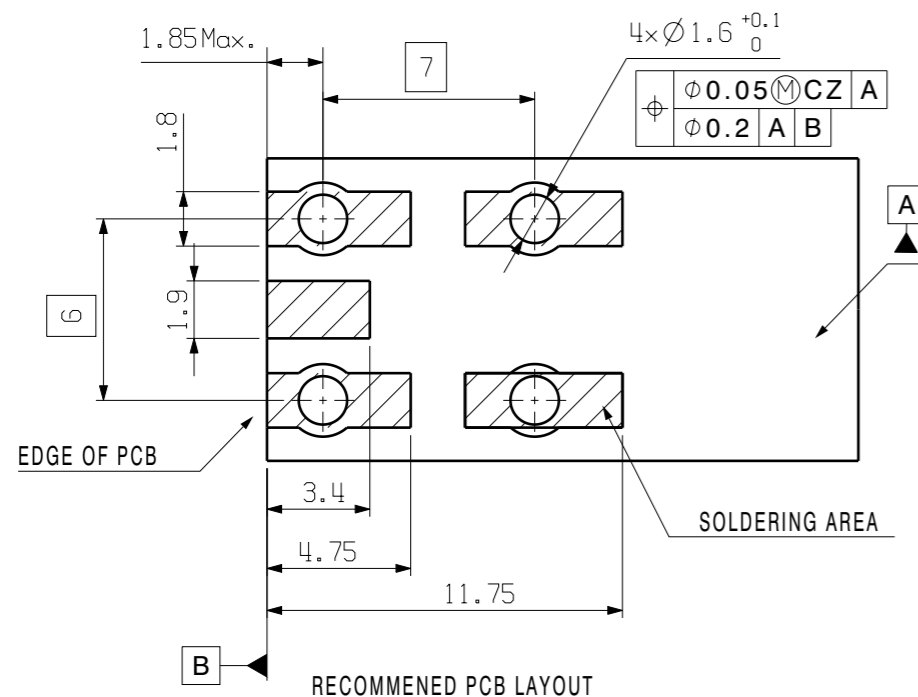

Shown as: 1FABN02HD1PK3MHF

1/1

VACUUM PICKING AREA

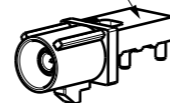

NOTE:

1. INTERFACE

ACC. TO DIN72594-1.THE CONFIGURATION OF THE CODINGS IS SHOWN ON SHEET 2.

2. ELECTRICAL DATE

IMPEDANCE	50 Ω
FREQUENCY	DC to 6 GHz
TEST VOLTAGE	750 V rms
WORKING VOLTAGE	335 V rms
POWER CURRENT	≤ 1 A DC

3. MECHANICAL DATA

MATING CYCLES	≥ 25
ENGAGEMENT FORCE	≤ 65 N
DISENGAGEMENT FORCE	≥ 2 N
RETENTION FORCE	≥ 110 N
CODING EFFICIENCY	≥ 40 N

4. ENVIRONMENTAL DATA

TEMPERATURE RANGE	-40 °C to +105 °C
THERMAL SHOCK	DIN 72594-2 clause 8.2
TEMPERATURE AND HUMIDITY	DIN 72594-2 clause 8.3
VIBRATION AND MECHANICALSHOCK	DIN 72594-2 clause 8.1
DRY HEAT	DIN 72594-2 clause 8.4
SOLDERING PROFILE	ACC. to IEC 60068-2-58 group 3&4
RoHS /HALOGEN FREE	COMPLIANT

5. MATERIAL AND PLATING :

CORE PIN	BRASS	GOLD PLATING
CORE PIN HOLDER	PA 6T	BLACK
INTERFACE HOUSING	PA 6T	COLOR REFER TO DIN72594-1
OUTER HOUSING	Zn ALLOY	TIN PLATING

6. PACKAGE: TAPE REEL

GENERAL TOLERANCE		DRAWN	Michael Wu	11/05'19	SCALE	PART NO.	1FABN02HU1P*3MHF
X. ±0.30	x.° ±3.0°	CHECKED	Michael Wu	11/05'19	4/1	TITLE	FAKRA R/A SINGLE POLE PLUG
.X ±0.25	.x° ±2.0°	APPROVED	Sky He	11/05'19	UNITS	mm	CODE NORMAL ORIENTATION
.XX ±0.20		File NO.	FABN0201S				CUSTOMER DRAWING
.XXX ±0.10		REV.	蘇州祥龍嘉業電子科技股份有限公司				
SHEET	2/3	Q'TY	1	X2	Goldenconn Electronics Technology Co.,LTD		

此文件为双方检验的唯一标准  
This document is the only standard for inspection by both parties.

REV.	ECN.NO.	MODIFY.CONTENT	DATE
X1		/	10/25'19
X2		Revised drawing	11/5'19

CODE NORMAL ORIENTATION  
Shown as: 1FABN02HU1PK3MHF

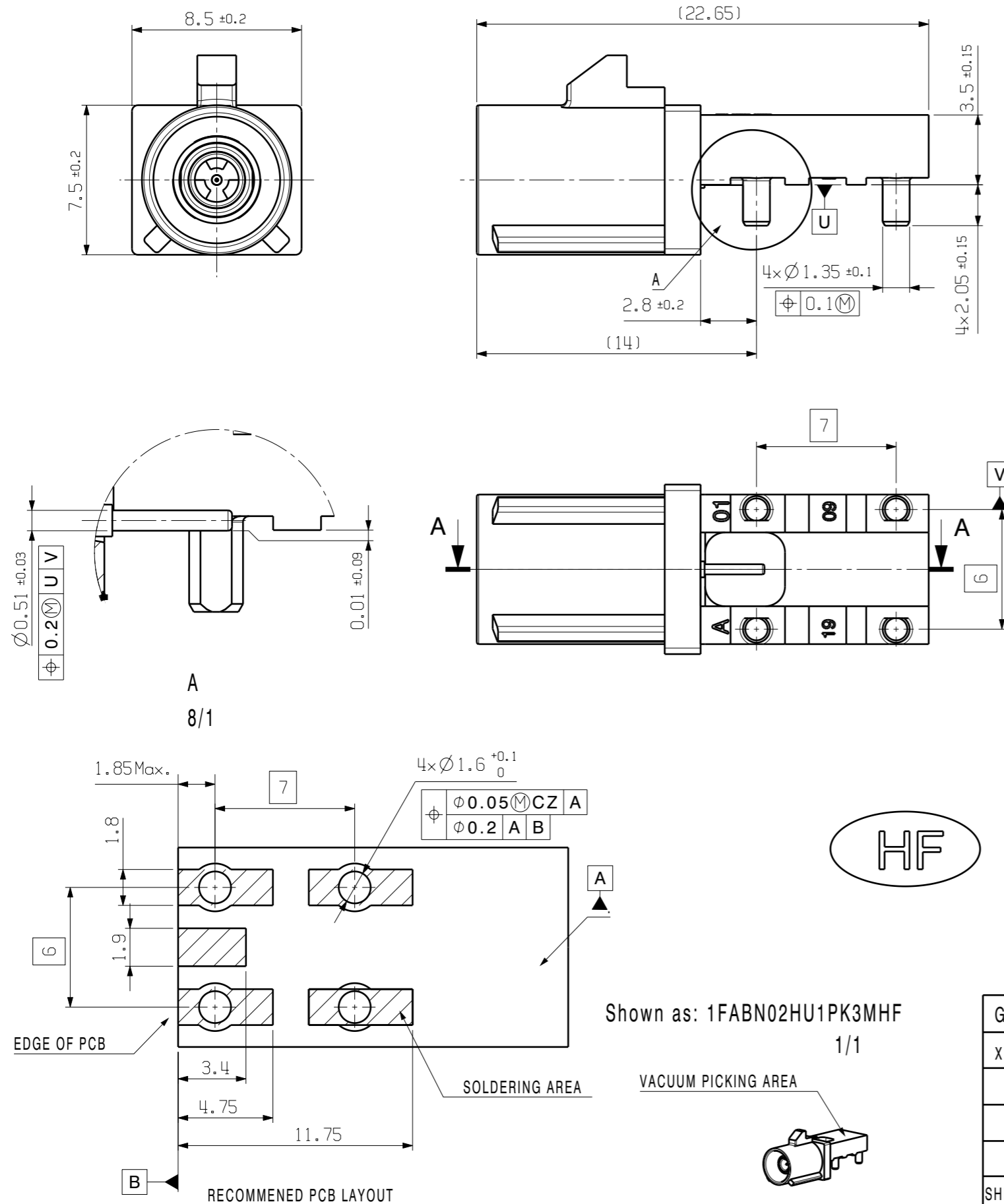

NOTE:

1. INTERFACE

ACC. TO DIN72594-1.THE CONFIGURATION OF THE CODINGS IS SHOWN ON SHEET 2.

2. ELECTRICAL DATE

IMPEDANCE	50 Ω
FREQUENCY	DC to 6 GHz
TEST VOLTAGE	750 V rms
WORKING VOLTAGE	335 V rms
POWER CURRENT	≤ 1 A DC

3. MECHANICAL DATA

MATING CYCLES	≥ 25
ENGAGEMENT FORCE	≤ 65 N
DISENGAGEMENT FORCE	≥ 2 N
RETENTION FORCE	≥ 110 N
CODING EFFICIENCY	≥ 40 N

4. ENVIRONMENTAL DATA

TEMPERATURE RANGE	-40 °C to +105 °C
THERMAL SHOCK	DIN 72594-2 clause 8.2
TEMPERATURE AND HUMIDITY	DIN 72594-2 clause 8.3
VIRBRATION AND MECHANICALSHOCK	DIN 72594-2 clause 8.1
DRY HEAT	DIN 72594-2 clause 8.4
SOLDERING PROFILE	ACC. to IEC 60068-2-58 group 3&4
RoHS /HALOGEN FREE	COMPLIANT

5. MATERIAL AND PLATING :

CORE PIN	BRASS	GOLD PLATING
CORE PIN HOLDER	PA 6T	BLACK
INTERFACE HOUSING	PA 6T	COLOR REFER TO DIN72594-1
OUTER HOUSING	Zn ALLOY	TIN PLATING

6. PACKAGE: TAPE REEL

GENERAL TOLERANCE		DRAWN	Michael Wu	11/05'19	SCALE	PART NO.	1FABN02HU1P*3MHF
X. ±0.30	x. °±3.0°	CHECKED	Michael Wu	11/05'19	4/1	TITLE	FAKRA R/A SINGLE POLE PLUG
.X ±0.25	.x °±2.0°	APPROVED	Sky He	11/05'19	UNITS	mm	CODE NORMAL ORIENTATION
.XX ±0.20		File NO.	FABN0201S				CUSTOMER DRAWING
.XXX ±0.10		REV.	蘇州祥龍嘉業電子科技股份有限公司				
SHEET	1/3	Q'TY	1	X2	Goldenconn Electronics Technology Co.,LTD		

此文件为双方检验的唯一标准  
This document is the only standard for inspection by both parties.

REV.	ECN.NO.	MODIFY.CONTENT	DATE
X1		/	10/25'19
X2		Revised drawing	11/5'19

ALL CODING RIBS SHOWN

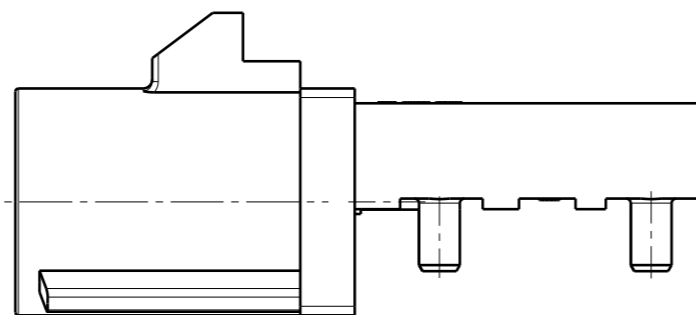
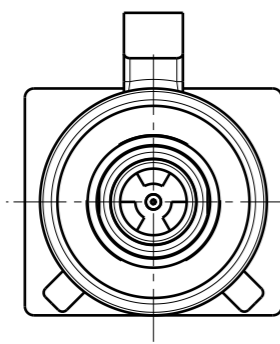

PRODUCT NAME RULE

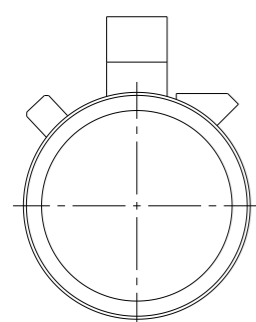
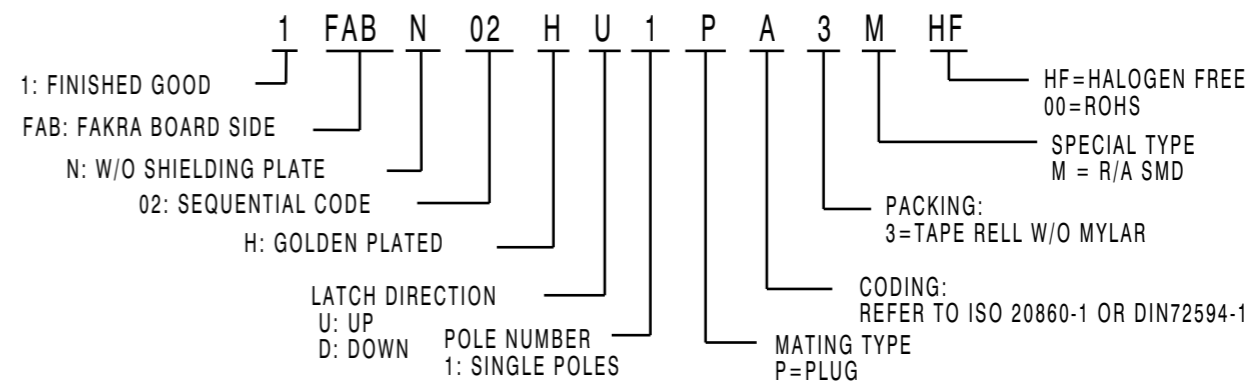

CODING A

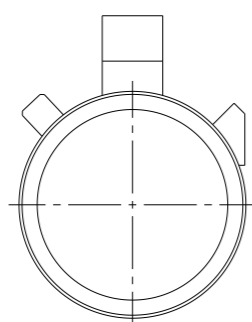

CODING B

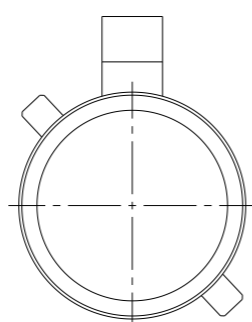

CODING C

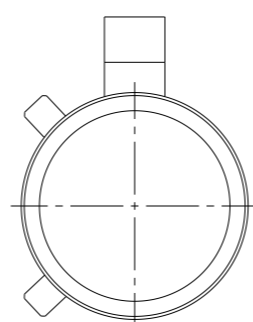

CODING D

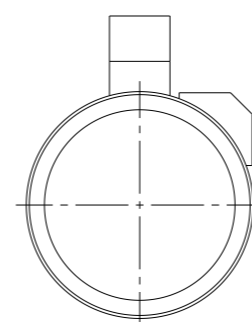

CODING E

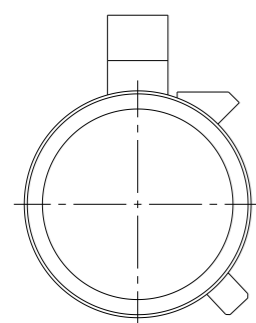

CODING F

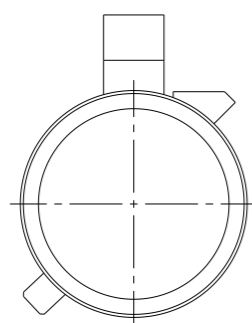

CODING G

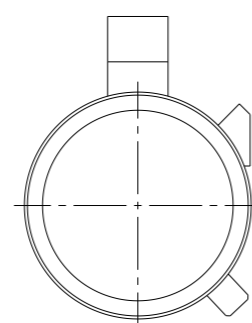

CODING H

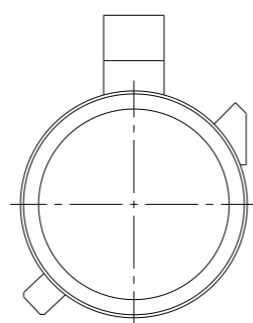

CODING I

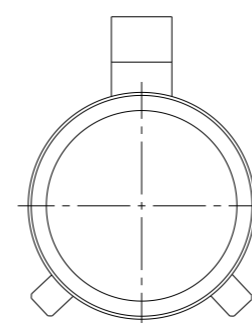

CODING K

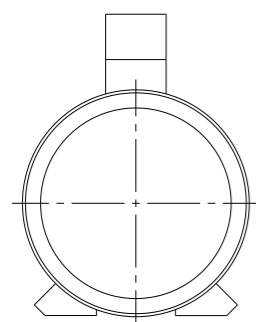

CODING L

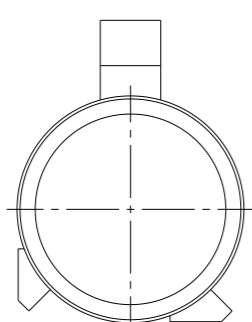

CODING M

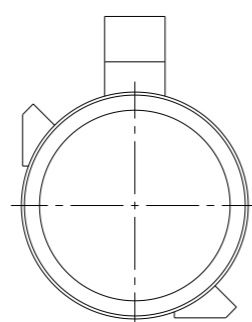

CODING N

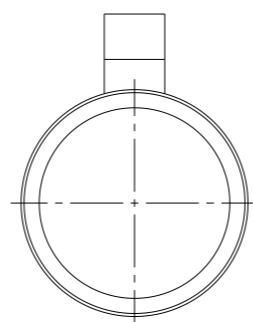

CODING Z



Coding	Color	RAL	Part Number
A	Black	RAL.9005	1FABN02H*1PA3MHF
B	White	RAL.9001	1FABN02H*1PB3MHF
C	Blue	RAL.5005	1FABN02H*1PC3MHF
D	Bordeaux violet	RAL.4004	1FABN02H*1PD3MHF
E	Green	RAL.6002	1FABN02H*1PE3MHF
F	Brown	RAL.8011	1FABN02HU*1PF3MHF
G	Gery	RAL.7031	1FABN02H*1PG3MHF
H	Violet	RAL.4003	1FABN02H*1PH3MHF
I	Beige	RAL.1001	1FABN02H*1PI3MHF
K	Curry	RAL.1027	1FABN02H*1PK3MHF
L	Carmine-red	RAL.3002	1FABN02H*1PL3MHF
M	Pastel-orange	RAL.2003	1FABN02H*1PM3MHF
N	White-green	RAL.6019	1FABN02H*1PN3MHF
Z	Water blue	RAL.5021	1FABN02H*1PZ3MHF

GENERAL TOLERANCE		DRAWN	Michael Wu	11/05'19	SCALE	PART NO.	1FABN02HU1P*3MHF
X.±0.30	x.*±3.0°	CHECKED	Michael Wu	11/05'19	4/1	TITLE	FAKRA R/A SINGLE POLE PLUG
.X±0.25	.x.*±2.0°	APPROVED	Sky He	11/05'19	UNITS	mm	CODE NORMAL ORIENTATION
.XX±0.20		File NO.	FABN0201S				CUSTOMER DRAWING
.XXX±0.10		REV.	蘇州祥龍嘉業電子科技股份有限公司				
SHEET	3/3	Q'TY	1	X2	Goldenconn Electronics Technology Co.,LTD		