

REV.	ECN. NO.	MODIFY. CONTENT	DATE
X1	**	**	2019-10-10

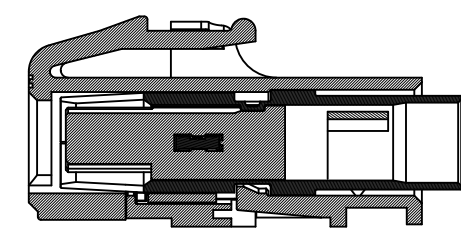

截面 A-A

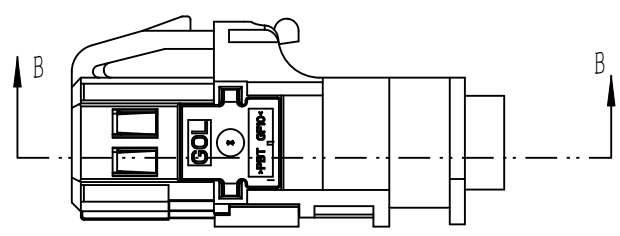
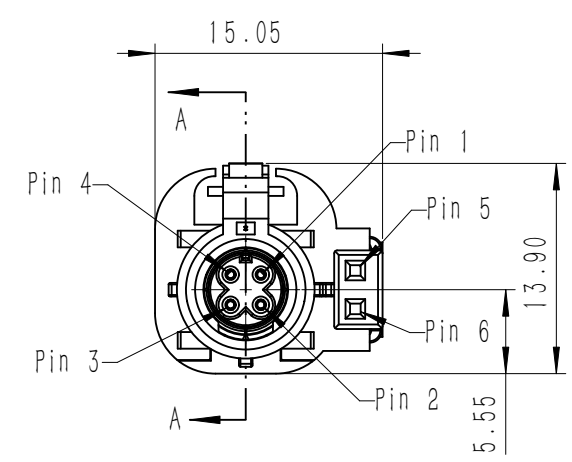
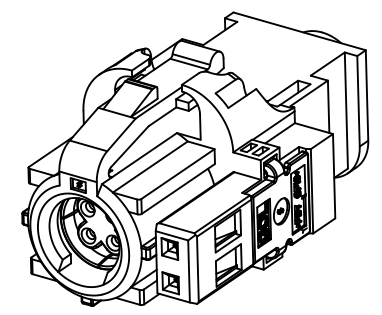
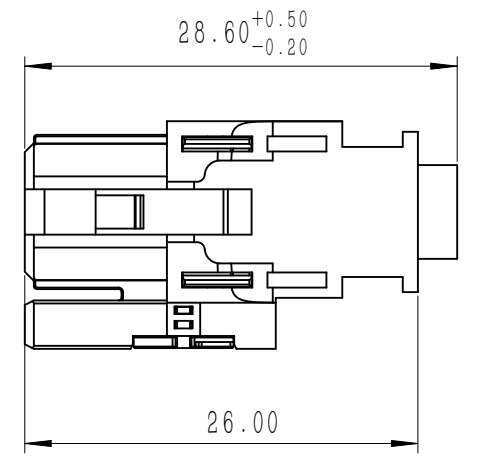
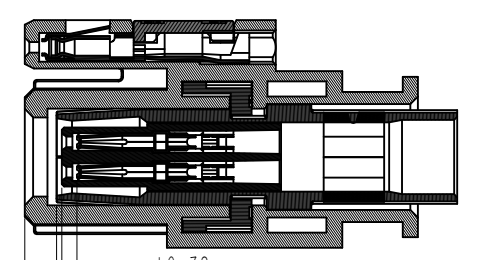
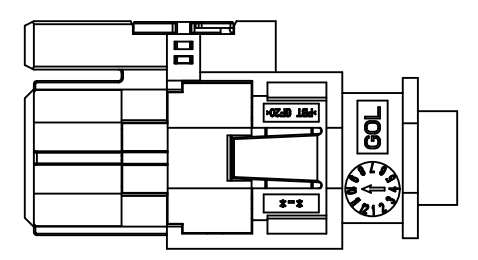

截面 B-B

技术要求:

1. 连接器颜色符合规定需求；
2. 电气性能:
  - a. 工作电压: 100 V rms;
  - b. 额定电流: 1.5 A DC;
  - c. 测试电压: 500 V rms;
  - d. 绝缘阻抗: 1000 MΩ Min.;
  - e. 内&外端子阻抗: 40 mΩ Max.。
3. 机械性能:
  - a. 插拔次数: 25 cycles;
  - b. 插入力: ≤60 N, 拔出力: 5 N Min.;
  - c. 卡扣保持力: 110N Min.;
4. 工作温度: -40~105℃;
5. 检验标志: ▼ 重要尺寸检验;
6. 成品料号及D/C镭雕刻印清晰, 字高1.5~2.5mm, 位置参考图示;
7. 环境有害物质符合欧盟ROHS环保要求。

GENERAL TOLERANCE		DRAWN	郭斌	2019-10-10	SCALE	PART NO.	***
X. ±0.15	X° ±1°	CHECKED			1:1	TITLE	***
.X ±0.10	.X° ±0.1°	APPROVED			UNITS	mm	***
.XX ±0.05		FILE NO.		***			***
.XXX ±0.03		REV.			苏州祥龙嘉业电子科技股份有限公司 Goldenconn Electronics Technology Co.,LTD		
SHEET 1/2	Q'TY 1	X1					

REV.	ECN. NO.	MODIFY. CONTENT	DATE
X1	**	**	2020-07-08

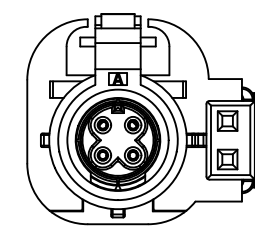
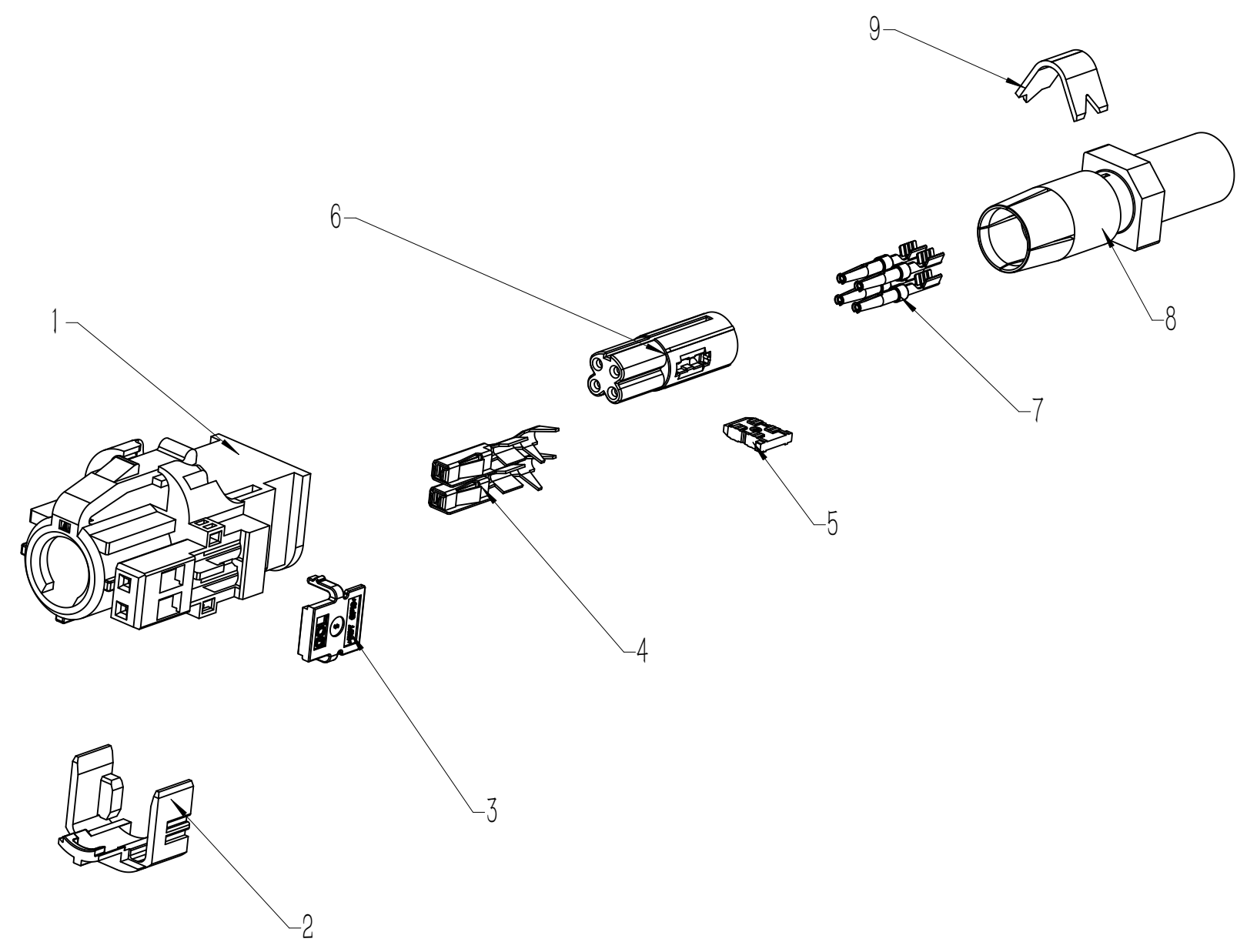

CODE A

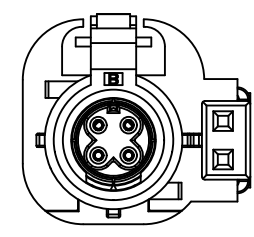

CODE B

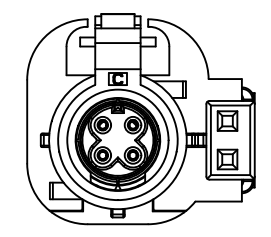

CODE C

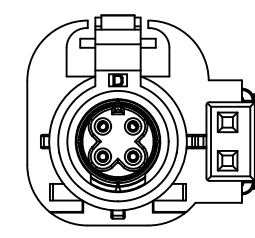

CODE D

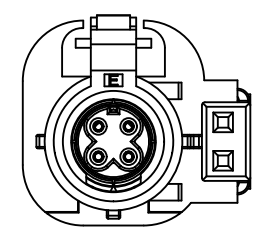

CODE E

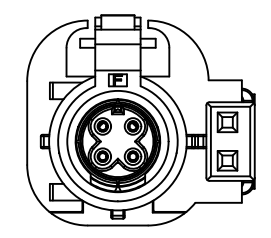

CODE F

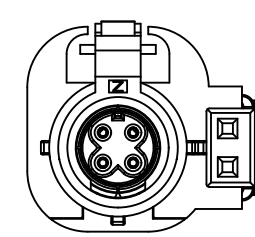

CODE Z

Item	Part Name	Part Number	Q'TY	Material	Plating
1	Coding Housing	2HSCN02B0601*-00	1	PBT GF20 RAL SEE TABLE 1	/
2	Second Lock	2HSCN02B04028-00	1	PBT GF20 RAL 4006	/
3	Power Second Lock	2HSCN01B06028-00	1	PBT GF20 RAL 4006	/
4	Power Contact	3TPBHSCN01T01-00	2	CuNiSi	Tin
5	Inner Lock	2HSCN02B04041-00	1	PA66 GF20 Black	/
6	Insulator	2HSCN02B04030-00	1	PA66 GF30 Black	/
7	Inner Conductor	2TPBHSCN02F01-00	4	C5210 R-H	0.025um Min Au over 1.25um Min Ni
8	Outer Conductor	3HSCN02MA0001-00	1	C3602	Ni 1.25~5um
9	Crimp	2TCBHSCN02T02-00	1	C2680 R-1/2H	2~3 um Sn

GENERAL TOLERANCE		DRAWN	郭斌	2020-07-08	SCALE	PART NO.	***
X.±0.15	X°±1°	CHECKED			2:1	TITLE	***
.X±0.10	.X°±0.1°	APPROVED			UNITS	mm	***
.XX±0.05		FILE NO.	***				***
.XXX±0.03		REV.	苏州祥龙嘉业电子科技股份有限公司 Goldenconn Electronics Technology Co.,LTD				
SHEET 2/2	Q'TY 1	X1					