

REV.	ECN.NO.	MODIFY.CONTENT	DATE
A	---	FIRST VERSION	03/14'18

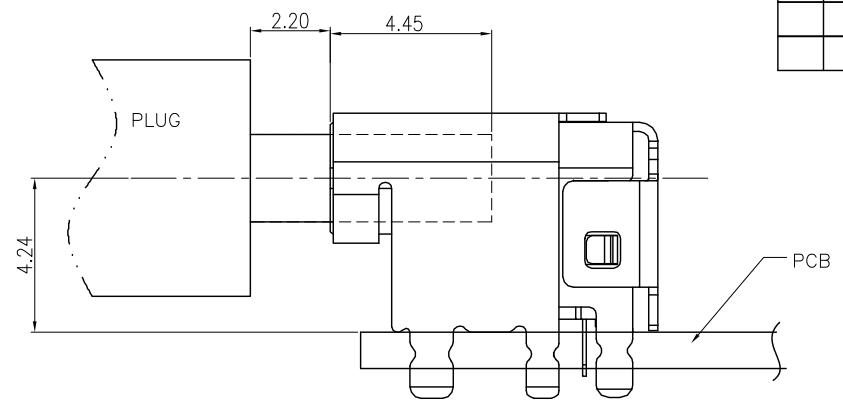

ASSEMBLY DWG

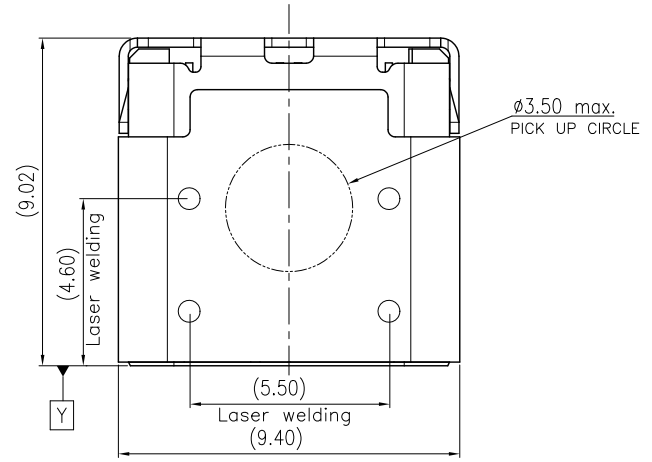
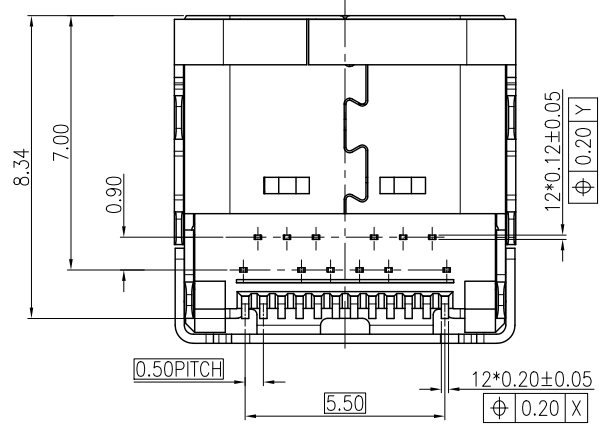
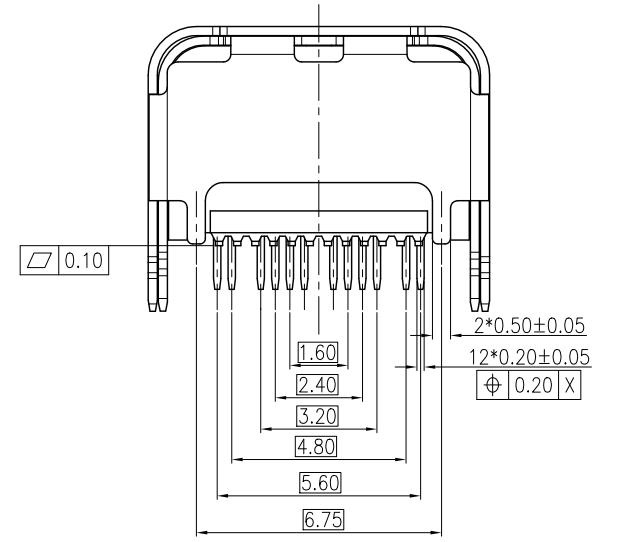
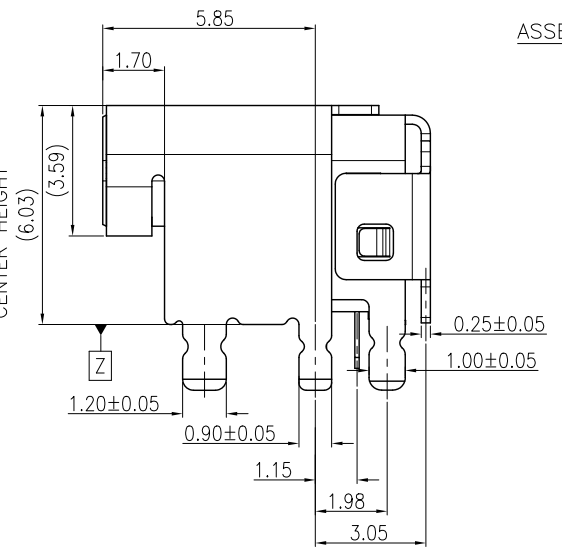
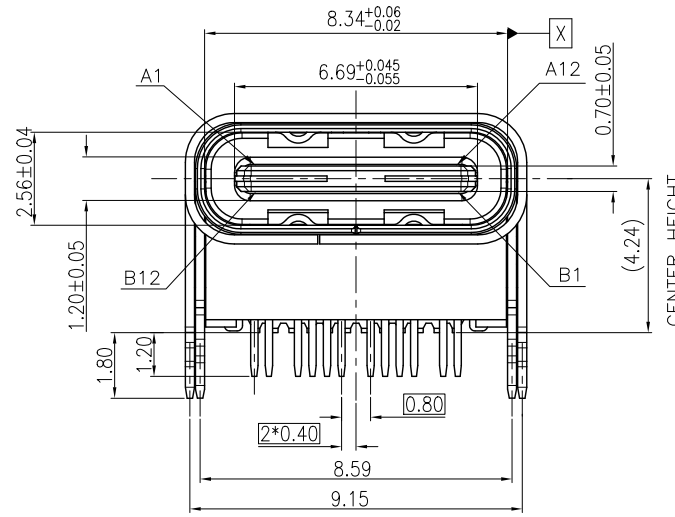

GENERAL TOLERANCE		DRAWN	WeiHong.Su	03/14'18	SCALE	PART NO.	1UBC032*24R*R-HF
X. $\pm 0.30$	x. $\pm 1^\circ$	CHECKED	Cunfa.Lai	03/14'18	N/A	TITLE	USB 3.1 TYPE C REC DIP&SMT
.XX $\pm 0.25$	.x $\pm 0.1^\circ$	APPROVED	Ray.Lee	03/14'18	UNITS	mm	成品SPEC图
.XXX $\pm 0.15$		File NO.	BUSCO3201S				
.XXX $\pm 0.10$		REV.	蘇州祥龍嘉業電子有限公司				
SHEET	1/2	Q'TY	1	A	Goldenconn Electronic Technology Co.,LTD		

