

REV.	ECN.NO.	MODIFY.CONTENT	DATE
A		FIRST VERSION	

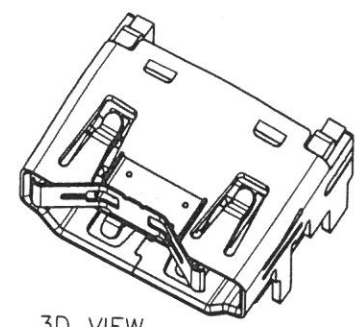

3D VIEW

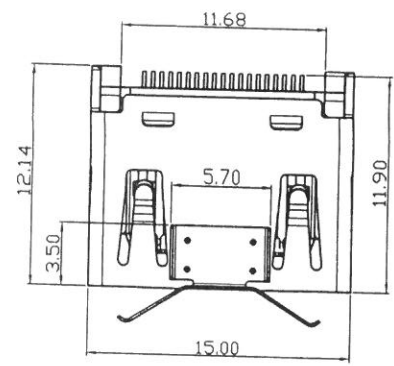
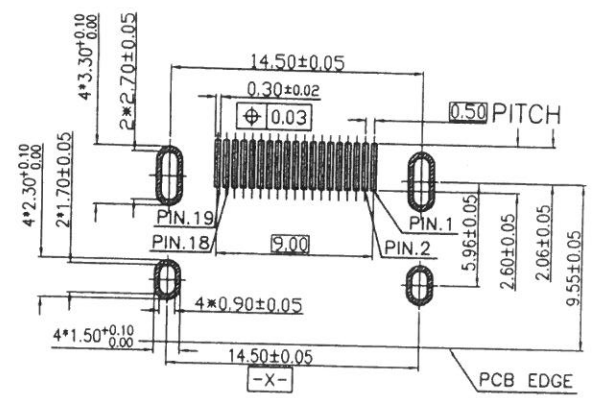

RECOMMENDED P.C.B. LAYOUT (T:1.20~1.60mm)
TOLERANCE UNSPECIFIED ±0.05mm

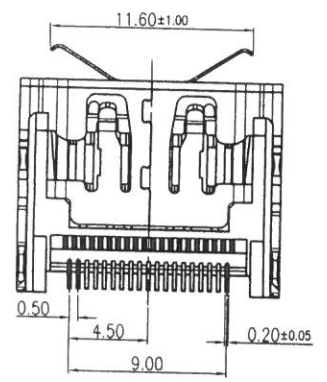
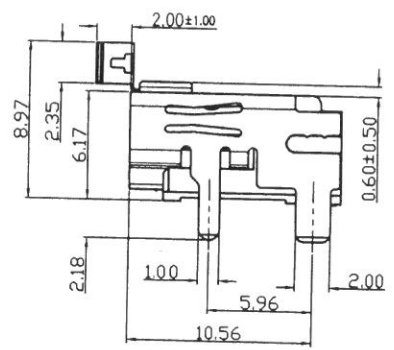
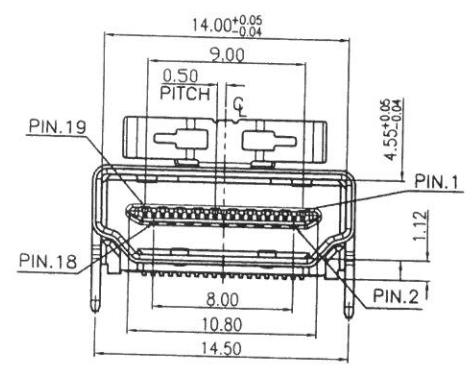

NOTES :

- MATERIAL :
BASE: LCP OR OTHER EQUIVALENT HIGH PERFORMANCE RESINS , UL94 V-0 RATED
TERMINAL : COPPER ALLOY
SHELL : STEEL OR OTHER EQUIVALENT PERFORMANCE ALLOY.
- PLATING:
SELECTIVE GOLD PLATING IN THE CONTACT AREA, AND SELECTIVE TIN PLATING IN THE SOLDER TAIL AREA WITH 60u" NICKEL UNDER PLATING OVERALL.
SHELL: PLATING 50u" NI
- PART NUMBER DESCRIPTION :
1HDM040 * 19 R 1 R-HF

Plating:
F:Gold Flash
E:Au:5u"
J:Au:15u"
K:Au:30u"

PIN NO.	SIGNAL ASSIGNMENT	PIN NO.	SIGNAL ASSIGNMENT
1	TMDS Data2+	2	TMDS Data2 Shield
3	TMDS Data2-	4	TMDS Data1+
5	TMDS Data1 Shield	6	TMDS Data1-
7	TMDS Data0+	8	TMDS Data0 Shield
9	TMDS Data0-	10	TMDS Clock+
11	TMDS Clock Shield	12	TMDS Clock-
13	CEC	14	Utility
15	SCL	16	SDA
17	DDC/CEC Ground	18	+5V Power
19	Hot Plug Detect		

GENERAL TOLERANCE		DRAWN	SCALE	PART NO.	1HDM040F19R1R-HF
X.±0.30	x.*±2.0'	CHECKED	1:1	TITLE	HDMI SOCKET R/A SMT 19PIN WITH SHRAPNEL,SHELL DIP
.X±0.25	.x*±1.0'	APPROVED	UNITS	mm	CUSTOMER DRAWING
.XX±0.15	.xx*±0.5'	File NO.	HDM04001S		
.XXX±0.10		REV.			
SHEET	1/2	QTY	1	A	

蘇州祥龍嘉業電子科技股份有限公司
Goldenconn Electronics Technology Co.,LTD

此文件为双方检验的唯一标准
This document is the only standard for inspection by both parties.

REV.	ECN.NO.	MODIFY.CONTENT	DATE
A		FIRST VERSION	

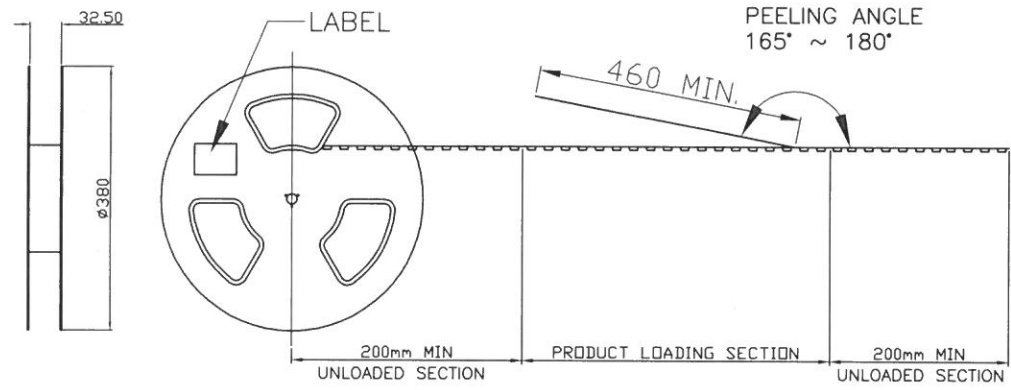

- NOTES :
- MATERIAL :
COVER TAPE : P.S T=0.05mm
CARRIER TAPE : P.S T=0.40mm
CARTON: CORRUGATED FIBER
 - DIMENSION :
REEL : SEE DRAWING
SHIPPING BOX: 400X400X300mm
 - QUANTITY : SEE TABLE
 - PEELING RESISTANCE : 10gf~130gf (for 12~56mm)
 - PEELING SPEED : 300mm/MINUTES

User Direction of Unreeling

PULL OUT DIRECTION

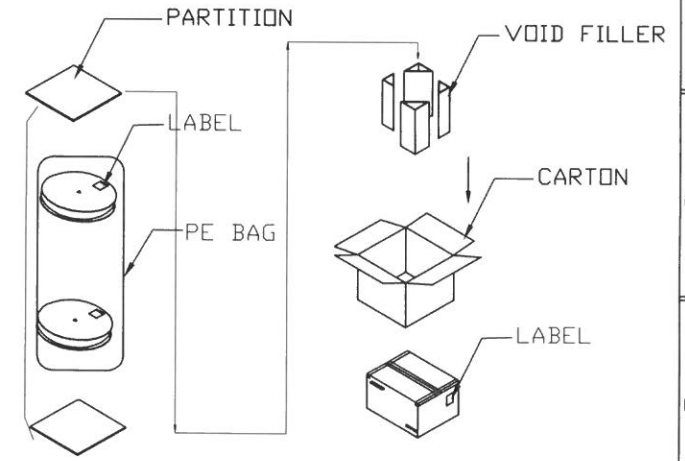
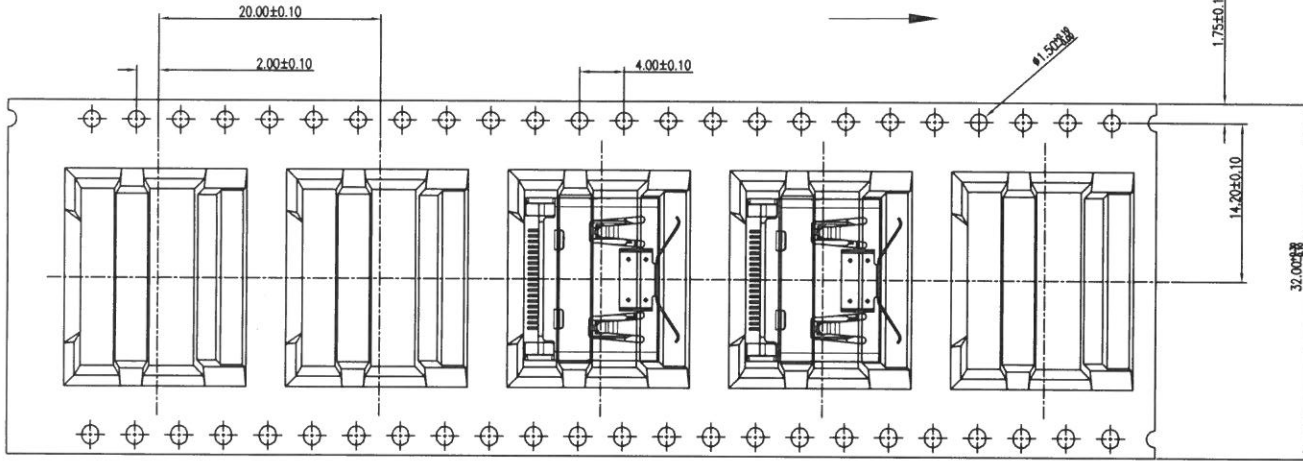

350	9	3150
PCS/REEL	REEL/BOX	TOTAL Q'TY

GENERAL TOLERANCE		DRAWN	3/28/20	SCALE	PART NO.	1HDM040F19R1R-HF
X±0.30	x.'±2.0'	CHECKED	3/28/20	1:1	TITLE	HDMI SOCKET R/A SMT 19PIN WITH SHRAPNEL, SHELL DIP
.X±0.25	.x'±1.0'	APPROVED	3/28/20	UNITS	mm	CUSTOMER DRAWING
.XX±0.15	.xx'±0.5'	File NO.	HDM04001S			
.XXX±0.10		REV.				
SHEET	2/2	Q'TY	1	REV.	蘇州祥龍嘉業電子科技股份有限公司 Goldenconn Electronics Technology Co.,LTD	

此文件为双方检验的唯一标准
This document is the only standard for inspection by both parties.