

此文件为双方检验的唯一标准  
This document is the only standard for inspection by both parties

REV.	ECN.NO.	MODIFY.CONTENT	DATE
X1		初版发行	12/12'18
X2		SWITCH 接触调整 滑块上增加LATCH X2	12/28'18

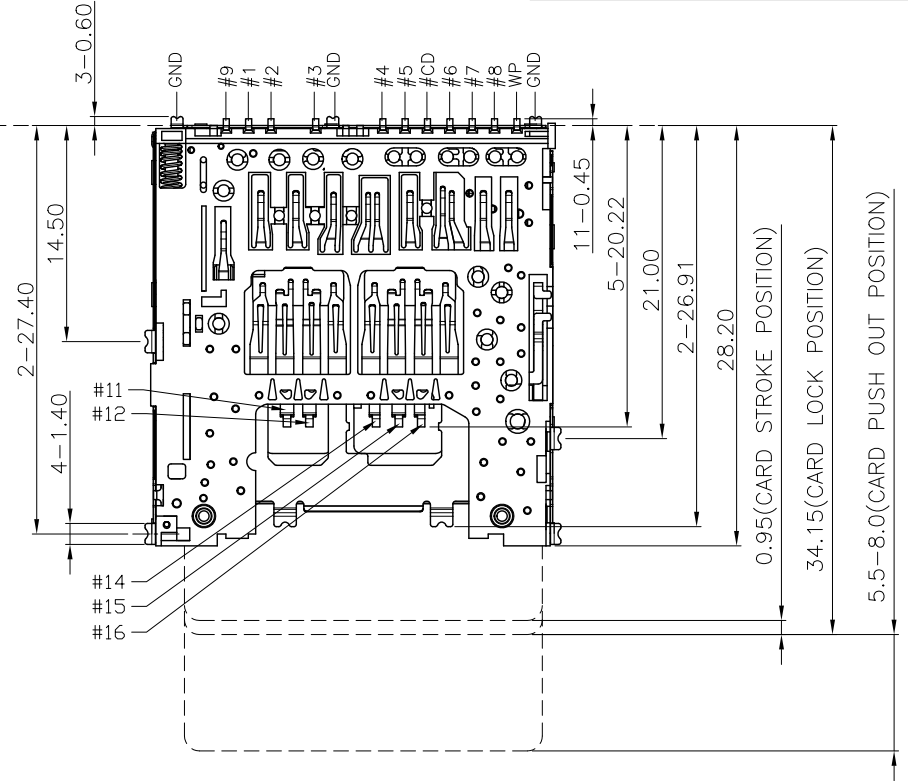
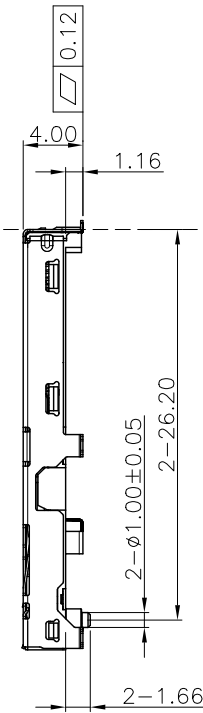
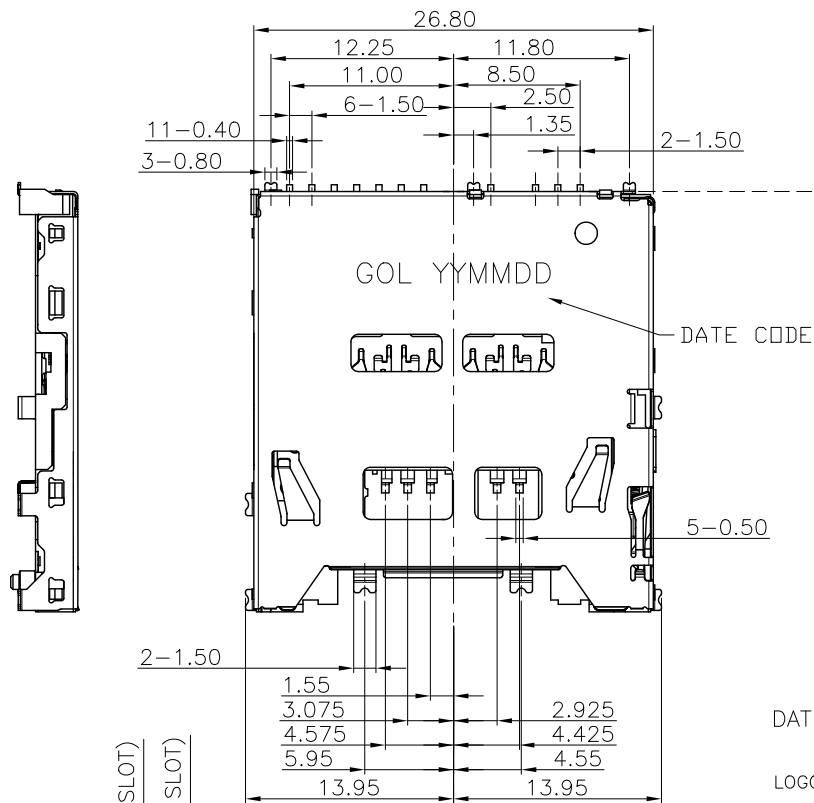

DATE CODE:  
GOL YY MM DD  
LOGO  
YY: Year  
MM: Month  
DD: Date

NOTES:

- MATERIAL:  
HOUSING: LCP, UL94V-0, BLACK.  
SLIDER : LCP, UL94V-0, BLACK  
TERMINAL: COPPER ALLOY.  
SHELL & HOOK & SPRING: STAINLESS STEEL.
- PLATING:  
TERMINAL: GOLD FLASH ON CONTACT AREA.  
MATTE TIN PLATED 100 U" MIN. ON SOLDER AREA.  
NICKEL UNDERPLATED 50 U" MIN. OVER ALL.  
SHELL: NICKEL UNDER PLATED 30 U" MIN. OVER ALL.
- PRODUCT COMPLIANT TO ROHS AND HALOGEN FREE.



	WRITE PROTECT SWITCH		CARD DETECT SWITCH
	WRITE PROTECT POSITION	WRITE ENABLE POSITION	
CARD UNINSERTION	OPEN	OPEN	OPEN
CARD HALF INSERTION	CLOSE	CLOSE	OPEN
CARD INSERTION	OPEN	CLOSE	CLOSE
N/O	OPEN		CLOSE

ITEM	PART NAME	MATERIAL	FINISH/COLOR	QTY
⑦	LATCH	STAINLESS STEEL	/	1
⑥	HOOK	STAINLESS STEEL	Ni PLATING	1
⑤	SPRING	STAINLESS STEEL	Ni PLATING	1
④	SOLDER	THERMOPLASTIC	UL 94-V0 ,BLACK	1
③	CONTACT	COPPER ALLOY	CONTACT AREA:GOLD FLASH SOLDERTAIL AREA:MATTE TIN	1SET
②	SHELL	COPPER ALLOY	Ni PLATING	1
①	HOUSING	THERMOPLASTIC	UL 94-V0 ,BLACK	1
ITEM	PART NAME	MATERIAL	FINISH/COLOR	QTY

GENERAL TOLERANCE		DRAWN	WH Su	12/28'18	SCALE	PART NO.	1SDA027F11R1R-HF
X.±0.40	x.°±1'	CHECKED	Ray.Lee	12/28'18	4:1	TITLE	SD4.0 PUSH PUSH CARD,H=4.0
.X±0.30	.x°±0.1'	APPROVED	Murray.Lu	12/28'18	UNITS	mm	CUSTOMER DRAWING
.XX±0.25		File NO.	SDA02701S				
.XXX±0.10		REV.	<b>蘇州祥龍嘉業電子科技股份有限公司</b> Goldenconn Electronics Technology Co.,LTD				
SHEET	1/3	Q'TY	1	X2			



REV.	ECN.NO.	MODIFY.CONTENT	DATE
X1		初版发行	12/12'18
X2		SWITCH 接触调整 滑块上增加LATCH	12/28'18

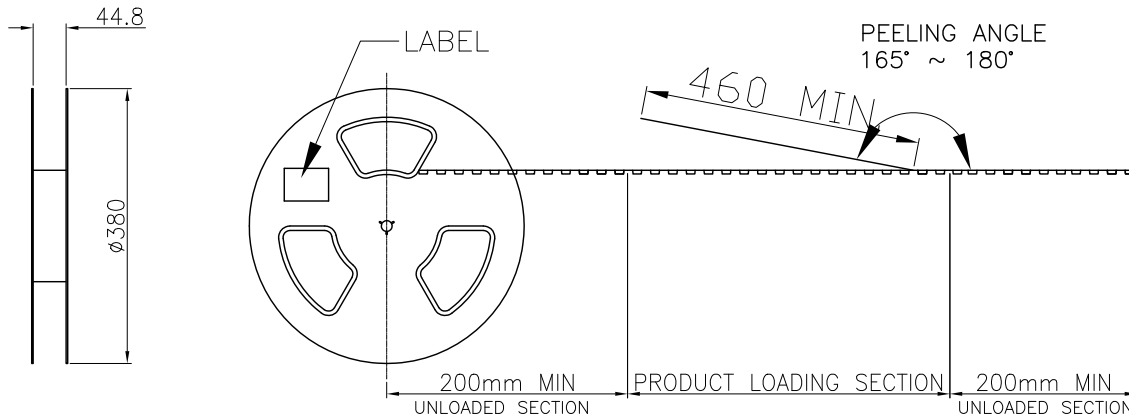

NOTES :

- MATERIAL :  
COVER TAPE : P.S T=0.05mm  
CARRIER TAPE : P.S T=0.40mm  
CARTON: CORRUGATED FIBER
- DIMENSION :  
REEL : SEE DRAWING  
SHIPPING BOX: 400X400X300mm
- QUANTITY : SEE TABLE
- PEELING RESISTANCE : 10gf~130gf (for 12~56mm)
- PEELING SPEED : 300mm/MINUTES

PULL OUT DIRECTION

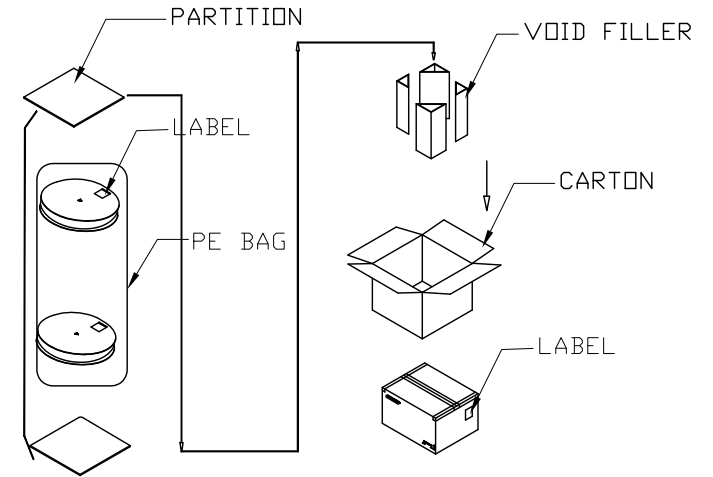
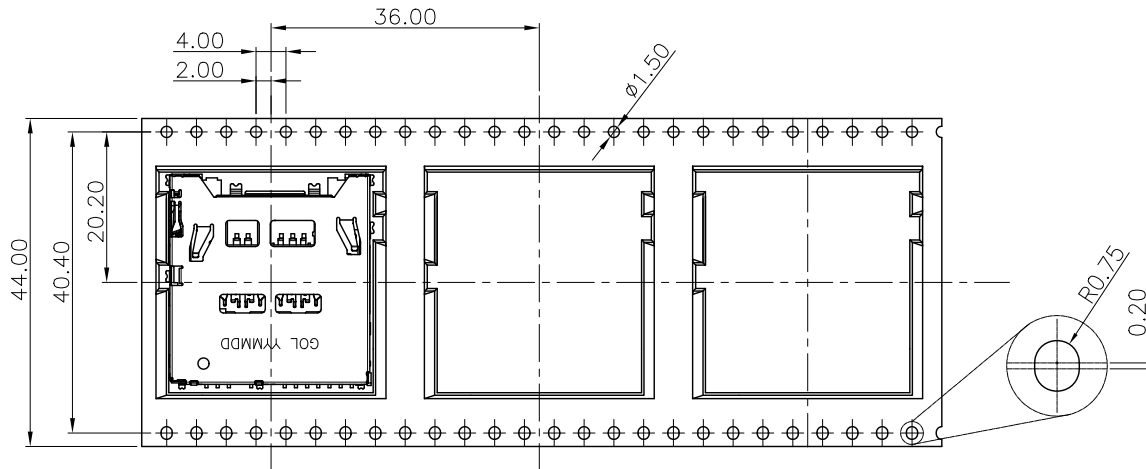

400	5	2000
PCS/REEL	REEL/BOX	TOTAL Q'TY

GENERAL TOLERANCE		DRAWN	WH Su	12/28'18	SCALE	PART NO.	1SDAO27F11R1R-HF
X.±0.40	x.°±1°	CHECKED	Ray.Lee	12/28'18	N/A	TITLE	SD4.0 PUSH PUSH CARD,H=4.0
.XX±0.30	.x°±0.1°	APPROVED	Murray.Lu	12/28'18	UNITS	mm	CUSTOMER DRAWING
.XX±0.25		File NO.	SDAO2701S				
.XXX±0.10		REV.					
SHEET	3/3	Q'TY	1	X2	<b>蘇州祥龍嘉業電子科技股份有限公司</b> Goldenconn Electronics Technology Co.,LTD		

